

Spherical roller bearings

Spherical roller bearings operate in arduous conditions.

The spherical rollers can be symmetrical or unsymmetrical and are self-aligning in the outer ring sphered raceway. Thus, the possible co-axiality deviations of the supporting bearings as well as shaft bending can be compensated.

Spherical roller bearings are manufactured in the following constructive versions, depending on the bearing size and series:

MB design

These bearings have a central fixed rib and machined cages guided on the inner ring rib.

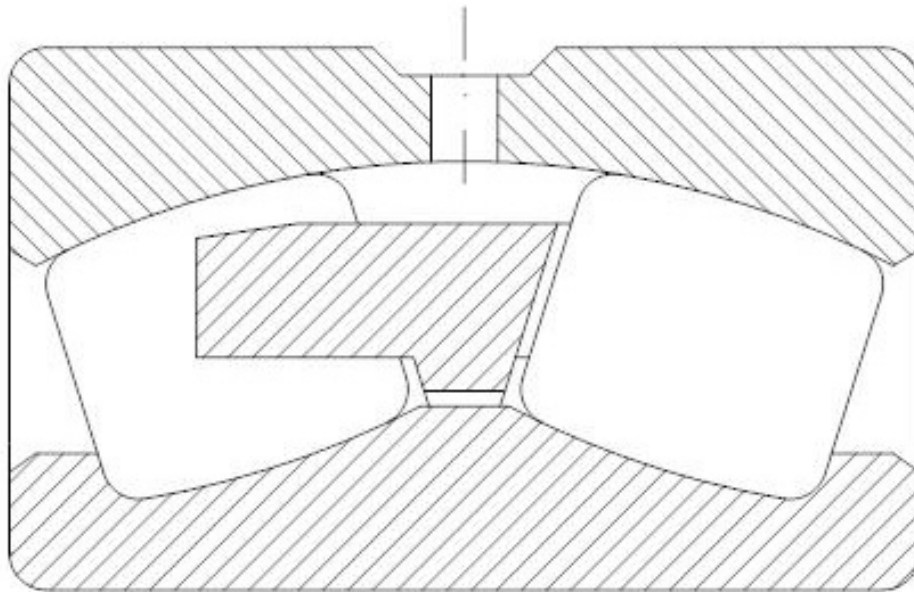

C design

These bearings have a central guide rib floating on the inner ring, symmetrical rollers with larger dimensions so that the load carrying capacity increases. Special pressed sheet cage. Bearings of this design are of small and medium sizes.

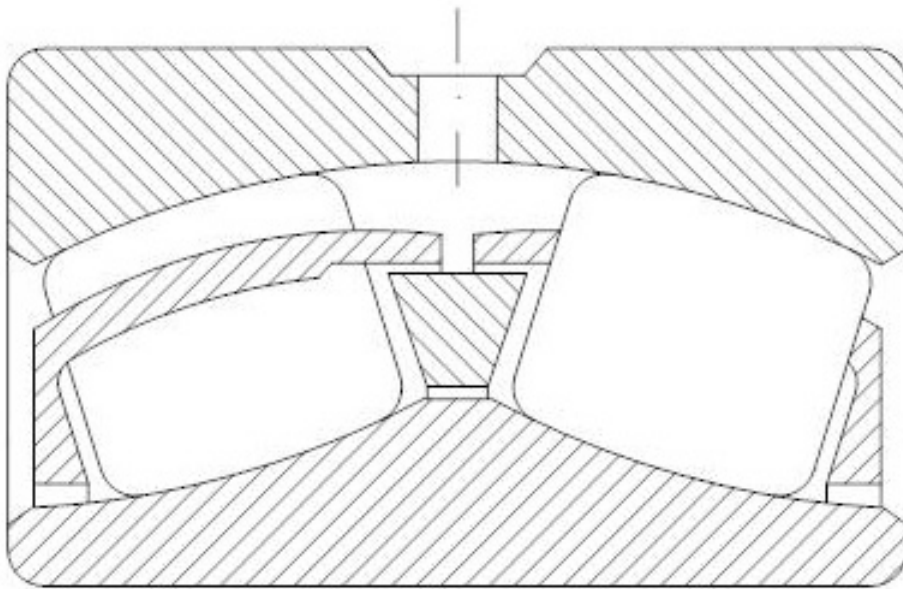

CA design

These bearings have side shoulders and one-piece machined brass cage. They also have symmetrical rollers with larger dimensions so that the load carrying capacity increases. This design is available for medium and large-sized bearings.

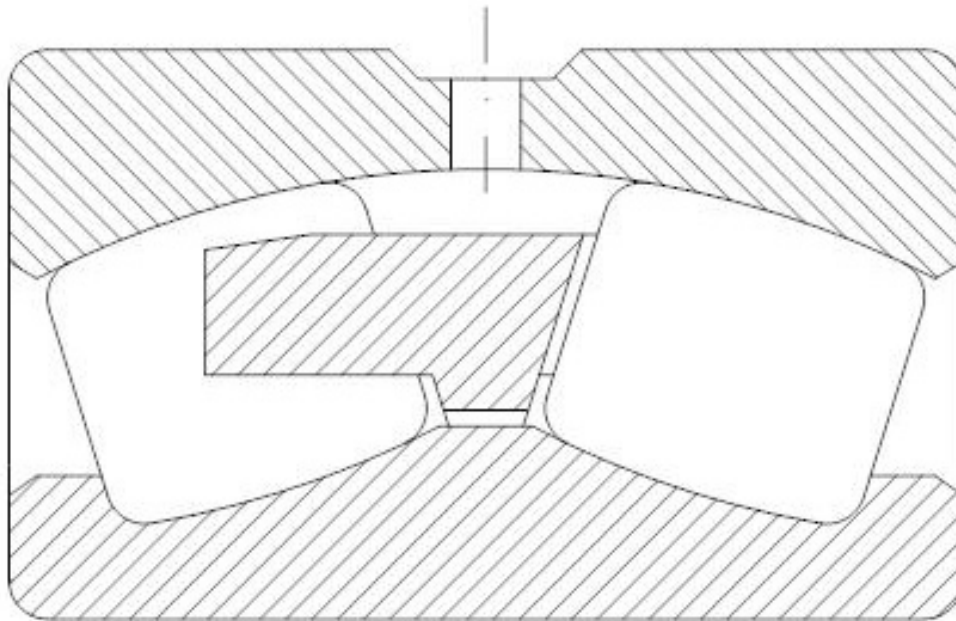

Other constructive versions are shown below:
cylindrical bore, lubrication groove and holes in the outer ring

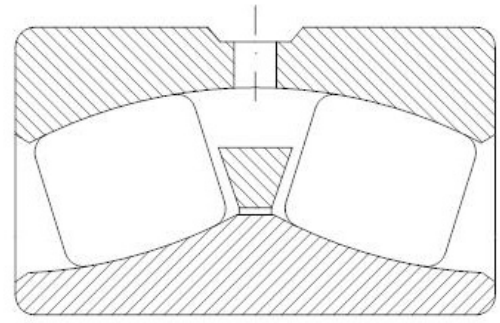
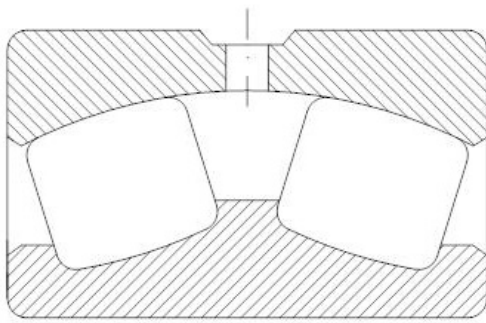

tapered bore, lubrication groove and holes in the outer ring
(taper 1:12, 1:30)

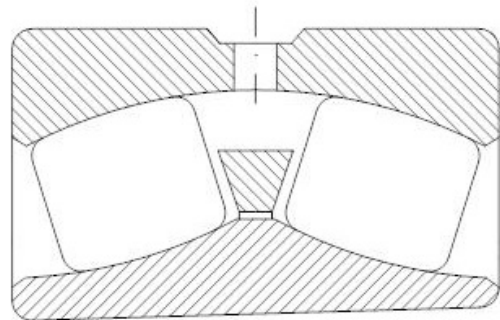
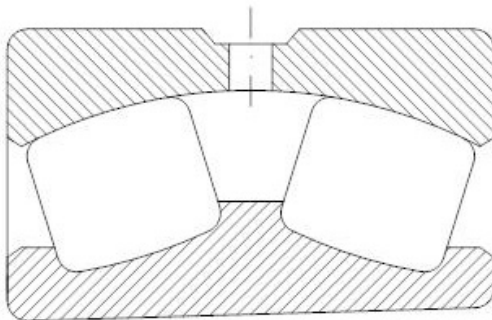

Suffixes

- C** - modified inner design, increased basic load, symmetrical rollers, pressed sheet cage
- CA** - modified inner design, increased basic load, one-piece machined brass cage
- F2, F3** - constructive modifications
- K** - tapered bore bearings, taper 1:12
- K30** - tapered bore bearings, taper 1:30
- MA** - machined brass cage guided on the outer ring
- MB** - machined brass cage guided on the inner ring
- P** - two-pieces outer ring
- W33** - lubrication groove and holes in the outer ring

Tolerances

Spherical roller bearings with both cylindrical and tapered bore, are manufactured in normal tolerance class (see chapter *BEARINGS TOLERANCES*)

Radial clearance

Spherical roller bearings are generally manufactured with normal radial clearance. At request, they can be manufactured with clearances larger than normal (C3, C4 etc.) or smaller than normal (C2).

The limits values of the radial clearance measured on unloaded bearings are in accordance with SR ISO 5753 and are given in table 1 and 2.

Radial clearance of spherical roller bearings

with cylindrical bore

Table 1

Bore diameter d		Radial clearance									
		C2		Normal		C3		C4		C5	
over	up to	min.	max.	min.	max.	min.	max.	min.	max.	min.	max.
mm		µm									
14	18	10	20	20	35	35	45	45	60	60	75
18	24	10	20	20	35	35	45	45	60	60	75
24	30	15	25	25	40	40	55	55	75	75	95
30	40	15	30	30	45	45	60	60	80	80	100
40	50	20	35	35	55	55	75	75	100	100	125
50	65	20	40	40	65	65	90	90	120	120	150
65	80	30	50	50	80	80	110	110	145	145	180
80	100	35	60	60	100	100	135	135	180	180	225
100	120	40	75	75	120	120	160	160	210	210	260
120	140	50	95	95	145	145	190	190	240	240	300
140	160	60	110	110	170	170	220	220	280	280	350
160	180	65	120	120	180	180	240	240	310	310	390
180	200	70	130	130	200	200	260	260	340	340	430
200	225	80	140	140	220	220	290	290	380	380	470
225	250	90	150	150	240	240	320	320	420	420	520
250	280	100	170	170	260	260	350	350	460	460	570
280	315	110	190	190	280	280	370	370	500	500	630
315	355	120	200	200	310	310	410	410	550	550	690
355	400	130	220	220	340	340	450	450	600	600	750

Radial clearance of spherical roller bearings
with tapered bore

Table 2

Bore diameter d		Radial clearance									
		C2		Normal		C3		C4		C5	
over	up to	min.	max.	min.	max.	min.	max.	min.	max.	min.	max.
mm		µm									
10	24	15	25	25	35	35	45	45	60	60	75
24	30	20	30	30	40	40	55	55	75	75	95
30	40	25	35	35	50	50	65	65	85	85	100
40	50	30	45	45	60	60	80	80	100	100	130
50	65	40	55	55	75	75	95	95	120	120	160
65	80	50	70	70	95	95	120	120	150	150	200
80	100	55	80	80	110	110	140	140	180	180	230
100	120	65	100	100	135	135	170	170	220	220	280
120	140	80	120	120	160	160	200	200	260	260	330
140	160	90	130	130	180	180	230	230	300	300	380
160	180	100	140	140	200	200	260	260	340	340	430
180	200	110	160	160	220	220	290	290	370	370	470
200	225	120	180	180	250	250	320	320	410	410	520
225	250	140	200	200	270	270	350	350	450	450	570
250	280	150	220	220	300	300	390	390	490	490	620
280	315	170	240	240	330	330	430	430	540	540	680
315	355	190	270	270	360	360	470	470	590	590	740
355	400	210	300	300	400	400	520	520	650	650	820

Dimensions

The main dimensions of spherical roller bearings are in accordance with ISO 15 and national standard SR 3918 respectively.

Misalignments

Spherical roller bearings allow angular misalignment between the outer ring and inner ring without any influence on the bearing rating life. Under normal loads and operating conditions and when the inner ring rotates, the values of the permissible misalignment depending on the bearing series are given in table 3.

Permissible angular misalignment

Table 3

Bearing series	Permissible angular misalignment
	degrees
213	1
222	1.5
223	2
230	1.5
231	1.5
232	2.5
239	1.5
240	2
241	2.5

Cages

Small and medium-sized spherical roller bearings are fitted with pressed sheet or machined brass cages (Y). Bearings of normal design are fitted with machined brass or steel cages guided on the rollers (M), inner ring (MB) or outer ring raceway (MA).

Glass fibre reinforced polyamide 6.6 cages are successfully used for small and medium size bearings if the operating temperature doesn't exceed +120°C.

Large-size bearings are fitted with machined brass cages, CA design.

Designs and some technical data are given in table 4.

Cage designs and some technical data

TABELUL 4

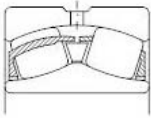
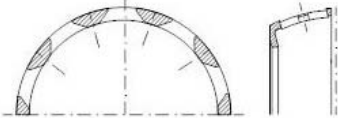
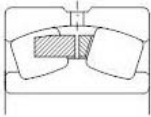
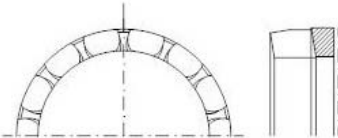
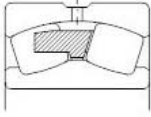
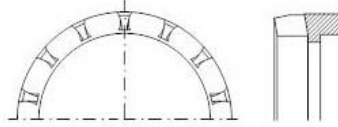
Denumire	Reprezentare Rulment	Colivie	Domeniu de aplicare	Valoare max.	
				$D_{m\dot{n}}$ ulei	unsoare
Colivie ambutisata din tabla			<ul style="list-style-type: none"> - Utilizare generala - Constructie C- - Turatii medii - Rulmenti cu $d \leq 200$ mm 	300×10^3	225×10^3
Colivie masiva din alama M sau otel F			<ul style="list-style-type: none"> - Utilizare generala - Rulmenti cu $d > 40$ mm 	350×10^3	265×10^3
Colivie masiva din alama, varianta CA			<ul style="list-style-type: none"> - Utilizare generala - Rulmenti cu $d > 200$ mm 	350×10^3	265×10^3

Lubrication grooves and holes

Spherical roller bearings are provided with a lubrication groove and holes in the outer ring, excepting those of series 213. Designation suffix W33 is used to identify this feature on bearings. The dimensions of the groove bore diameter and their number depending on the dimensions series are given in table 5.

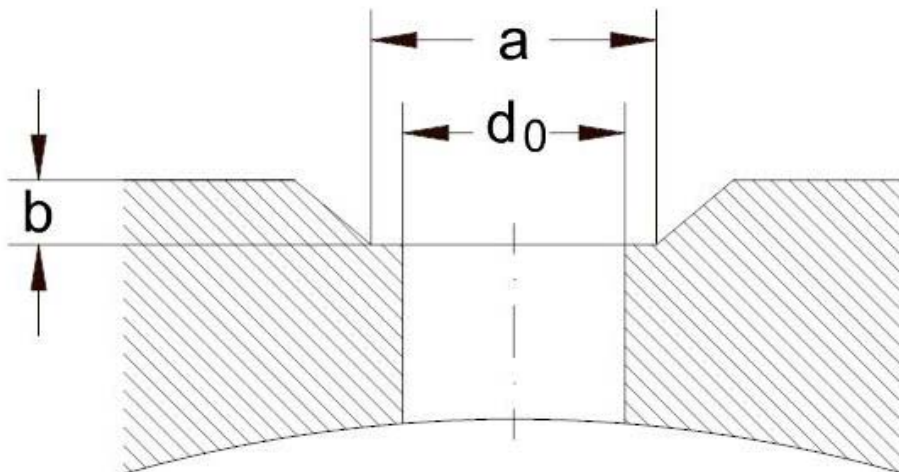

Dimensions of lubrication grooves and holes

Table 5

Series 23900				Series 23000				Series 24000			
Outer diameter range mm	Dimensions d ₀ mm	a	b	Outer diameter range mm	Dimensions d ₀ mm	a	b	Outer diameter range mm	Dimensions d ₀ mm	a	b
250... 320	4.5	7.21	1.5	170... 210	4.5	7.2	1.5	... 180	4.5	7.2	1.5
				225... 260	6	9.6	2	200... 225	6	9.6	2
				280... 290	7.5	12.1	2.5	240... 260	7.5	12.1	2.5
				310... 420	9	14.5	3	280... 400	9	14.5	3

Series 23100				Series 24100				Series 22200			
Outer diameter range mm	Dimensions d ₀ mm	a	b	Outer diameter range mm	Dimensions d ₀ mm	a	b	Outer diameter range mm	Dimensions d ₀ mm	a	b
165... 200	4.5	7.2	1.5	180... 210	3	4.9	1	85... 100	3	4.2	0.8
210... 250	6	9.6	2	... 225	4.5	7.2	1.5	110... 160	3	4.9	1
... 270	7.5	12.1	2.5	250... 270	4.5	9.6	2	170... 200	4.5	7.2	1.5
280... 440	9	14.5	3	280... 400	6	9.6	52	215... 250	6	9.6	2
								270... 290	7.5	12.1	2.5
								310... 360	9	14.5	3

Series 23200				Series 22300			
Outer diameter range mm	Dimensions d ₀ mm	a	b	Outer diameter range mm	Dimensions d ₀ mm	a	b
... 160	3	4.9	1	90... 120	3	4.9	1
190... 200	4.5	7.2	1.5	130... 180	4.5	7.2	1.5
215... 250	6	9.6	2	190... 215	6	9.6	2
270... 320	7.5	12.1	2.5	240... 260	7.5	12.1	2.5
340... 400	9	14.5	3	280... 360	9	14.5	3
				380... 420	12	19.7	3.5

Number of lubrication holes – all series			
Bore diameter range, mm	50... 240	260... 440	460... 950
Number of lubrication holes	3	4	6

Axial load for bearings mounted on adapter sleeves

If the spherical roller bearings are mounted on a smooth shaft using an adapter sleeve, without side support, the axial load carrying capacity depends on the friction between shaft and sleeve.

Considering that the mounting is correctly done, the permissible axial load can be accurately enough determined using the following equation:

$$F_{a \max} = 3 \cdot B \cdot d, \text{ kN}$$

where:

$F_{a \max}$ – maximum permissible axial load, kN,

B – bearing width, mm,

d – bearing bore diameter, mm,

Equivalent dynamic radial load

$$P_r = F_r + Y_1 * F_a, \text{ kN,} \quad \text{for } F_a/F_r \leq e,$$

$$P_r = 0.67 * F_r + Y_2 * F_a, \text{ kN,} \quad \text{for } F_a/F_r > e.$$

The values of the factors depending on the bearing type can be found in bearing tables.

Equivalent static radial load

$$P_{0r} = F_r + Y_0 * F_a, \text{ kN}$$

The values of the factor Y_0 depending on the bearing type can be found in bearing tables.

Abutment dimensions

For a proper location of bearing rings on the shaft and housing shoulder, respectively, shaft (housing) maximum connection radius $r_{u \text{ max}}$ should be less than bearing minimum mounting chamfer $r_{s \text{ min}}$.

Shoulder height should also be properly sized in case of bearing maximum mounting chamfer.

The values of the connection radii and support shoulder height are given in table 6. The mounting dimensions for bearings with withdrawal sleeves are given in table 7.

Abutment dimensions

Table 6

r_s min	r_u max	h_u min	
			Bearing series
		230	231, 213
		239	241, 223
		240	222, 233
			232
mm			
1	1	2.3	2.8
1.1	1	3	3.5
1.5	1.5	3.5	4.5
2	2	4.4	5.5
2.1	2.1	5.1	6
3	2.5	6.2	7
4	3	7.3	8.5
5	4	9	10
6	5	11.5	13
7.5	6	14	16
9.5	8	17	20